

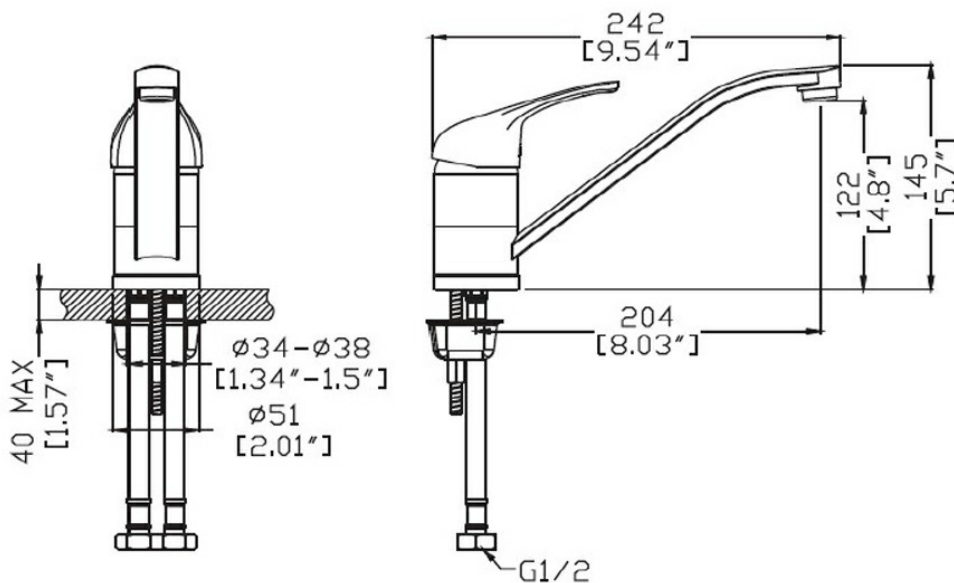











VERONA II KITCHEN MIXER CHROME

44182.02
\$285

ELEMENTi



	Check Stop	Ball valves with integrated check stop.
	Guarantee	10 Year Guarantee
	5 Star WELS rating	More than 4.5 but not more than 6 litres per minute
	Mains Pressure	Suitable for Mains Pressure.
	Multi Pressure	Suitable for Multi Pressure.
	Hose Tails	Mixer specifically designed for the Laundry with 450mm hose tails
	Swivel Spout	The Swivel spout provides space, flexibility and ease of use.
	BPIR - B2.3.1 Durability	This product complies with Building Code Regulation B2.3.1 Durability
	BPIR - G12.3.2 (A) G12 Water Supplies	This product complies with Building Code Regulation G12.3.2 (A) G12 Water Supplies
	BPIR - G12.3.2 (B) G12 Water Supplies	This product complies with Building Code Regulation G12.3.2 (B) G12 Water Supplies
	BPIR - G12.3.7 G12 Water Supplies	This product complies with Building Code Regulation G12.3.7 G12 Water Supplies

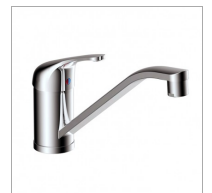

The Elementi Verona II Chrome Kitchen Mixer is an attractive, durable, and functional addition to your laundry or kitchen. With a focus on performance and style, this mixer is ideal for residential and light commercial use and can be the ideal addition to your kitchen, laundry, or even light commercial businesses such as hotels and motels.

With inbuilt check stops ball valves, Verona II is able to deliver consistent performance and backflow prevention. It has a 5 Star WELS rating, which offers efficient use of water without compromising performance with no performance compromise, between 4.5 but not exceeding 6 litres a minute.

This mixer is designed to function effectively with mains pressure and multi-pressure systems, thus the ease of use in the majority of water systems. The swivel spout creates sufficient space and room, thus making daily activities easier and convenient.

The Verona II comes with 450mm hose tails, specifically for laundry purposes, offering utility to any installation type. It meets the requirements of Building Code Regulation standards such as B2.3.1 Durability and G12 Water Supplies, offering support to the highest standards in the industry.

With 10-year warranties, this mixer is built to endure long, offering functionality, durability, and beauty to your every water application need.